

## 1. HEALTH AND SAFETY NOTES

This Boost Pump has been designed to be safe, however, it is important that personnel working on these units understand any potential dangers. All safety information detailed in this handbook is highlighted as WARNING and CAUTION instructions. These are used as follows:



**WARNING!** WARNINGS ARE GIVEN WHERE FAILING TO OBSERVE THE INSTRUCTION COULD RESULT IN INJURY OR DEATH TO PERSONS.



**CAUTION!** Cautions are given where failure to observe the instruction could result in damage to the equipment, associated equipment and processes.

## 2. COMPONENTS

- Chassis with Purity Meter, Conductivity Cell, Outlet Pipe and Filter Washer.
- Inlet Tube, Cap and Tap Connector.
- Battery, Type 9v PP3. (Not included).
- Four C114 Ion Exchange Cartridges.
- Wall Fixing Screws.

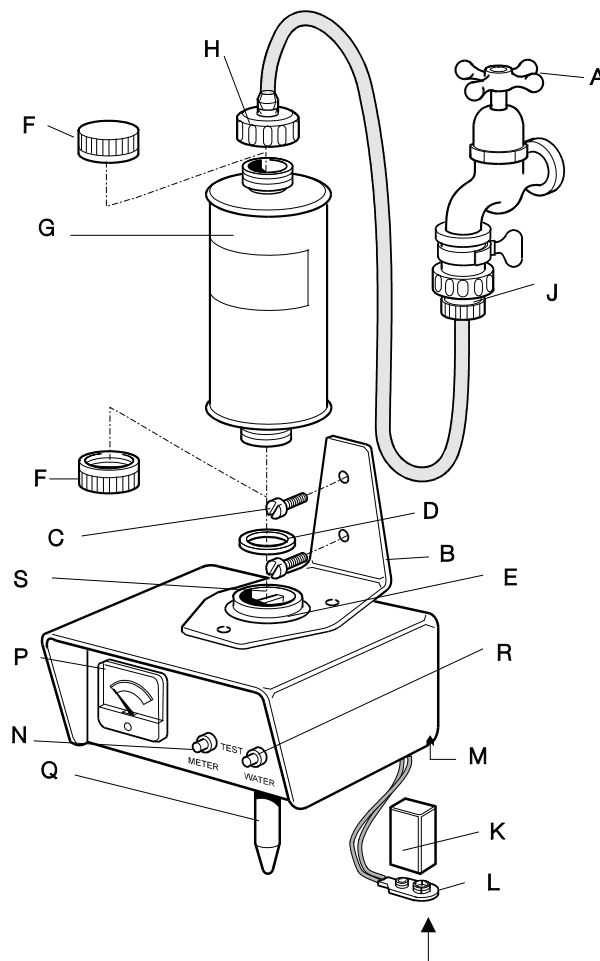

Maximum Input  
Water Pressure:

10.0 psi  
0.63 Bar

Max. Flow Rate  
30.0 l/hr

**Should input water pressure exceed the maximum, fit a pressure reducing valve.**

### 3. ASSEMBLY

Decide on location, preferably close to a cold potable water supply, tap (A) and over a sink or drain.

Fasten Chassis (B) securely to the wall about 5 feet (150 cm) above floor level, using Fixing Screws (C) provided.

Place Filter Washer (D) inside Threaded Coupling (E) on top of Chassis (B).

Carefully remove transit caps (F) from inlet and outlet ends of filter cartridge (G). Ensure foam filters inside cartridge are not disturbed.

#### DO NOT REMOVE FOAM FILTERS

Screw outlet end of cartridge into Threaded Coupling (E) on top of Chassis.

Screw Inlet Cap with Tubing (H) onto inlet end of cartridge.

Push Tap Connector (J) onto cold water tap (A) and screw tight. Connector is designed to fit standard ½" (12 mm) tap.

Remove cellophane wrapping from Battery (K) and push onto Red Connecting Plug (L) located underneath Chassis and push into Battery Housing (M).

When replacement is needed, pull down Red Tab and fit battery type 9v PP3.



#### WARNING:

THIS UNIT IS DESIGNED FOR FREE FLOWING  
DO NOT RESTRICT OUTLET IN ANY WAY.

### 4. DIRECTIONS FOR USE OPERATION

- 3.1 **TEST METER:** Press left-hand switch marked "meter test" (N). If meter needle (P) does not move into yellow zone, replace Battery (K) situated underneath Chassis.
- 3.2 **TURN ON TAP:** There will be a delay while Elgacan cartridge fills with water – await a steady flow from Outlet Pipe (Q).
- 3.3 **DISCARD FIRST HALF LITRE.**
- 3.4 **TEST WATER:** Press right-hand switch marked "water test" (R) and instantly observe meter reading (P).

N.B. should switch be held down for more than a second or two, meter needle will gradually move towards left side of meter face indicating a false reading. Water purity is registered by the immediate positioning of meter needle.

- 3.5 **WATER IS OF ACCEPTABLE QUALITY** when meter needle registers **IN GREEN ZONE**. **WATER IS OF UNACCEPTABLE QUALITY** when meter needle registers **IN RED ZONE**; the Elgacan is exhausted and should be replaced by a fresh one.

N.B. When unit is not used for some time the quality may fall temporarily. On drawing water is should recover almost immediately. If this is not the case your cartridge is exhausted and should be replaced



#### WARNING:

THIS UNIT IS DESIGNED FOR FREE FLOWING  
DO NOT RESTRICT OUTLET IN ANY WAY.

### CHANGING THE CARTRIDGE

1. Turn off water supply (A). Remove Tap Connector (J) from water supply.
2. Unscrew Inlet Cap with tubing (H) from Elgacan cartridge (G).
3. Unscrew Elgacan cartridge and discard.
4. Disconnect Battery (K).
5. Remove Filter Washer (D). Clean filter by flushing with tap water.
6. The conductivity Cell electrodes (S) may be observed inside Threaded coupling (E). Clean the **total** surface of each electrode using a pipe cleaner and water. Pay particular attention to the inside surfaces of the electrodes.

# ASSEMBLY INSTRUCTIONS



For B114

Reference Number: MANU30357

## DO NOT ATTEMPT TO REMOVE ELECTRODES

7. Replace Filter Washer, fit fresh Elgacan cartridge, reconnect Inlet Cap with Tubing and push Tap Connector onto Cold water tap. **Reconnect Battery.** Unit is now ready for operation.



**CAUTION:** Unless this very simple maintenance is carried out with meticulous care each time a cartridge is changed, meter readings will be adversely affected. False readings will cost you money, as you may believe the cartridge to be exhausted when it is not.

## CARTRIDGE SERVICE

Elgacan **C114** cartridges are available in standard packs (four Elgacans per pack) from your local Elga Agent or direct from The Elga Group.



  
PERTH SCIENTIFIC PTY LTD  
**Sales and Service**

Unit 2, 11 Narloo Street, Malaga, Western Australia 6090  
Tel: +618 6240 5600 Fax: +618 9209 3944  
E-mail: [sales@perthscientific.com.au](mailto:sales@perthscientific.com.au)